

*Cleaning technology  
Municipal technology  
Water jet technology*

**Hako**



## ***The Citymaster 2250***

***Large size for superior efficiency***

*Powerful. Compact. Multifunctional.*

## Comfortable and safe

Spacious, optimally air-conditioned – and particularly safe: the crash-tested cabin with highly efficient air-conditioning, intuitive operating concept and sophisticated safety features.

**„This is exactly how a spacious workplace should look like!“**

## Large!

The cabin has been designed for the operator and impresses not only with its generous space but also with its possibilities: the interior equipment can be individually adapted.

## XXL performance

More efficiency, numerous applications – thanks to the multifunctional design: as a sweeper with additional benefits, the Citymaster 2250 can also be used for other tasks to ensure full utilisation of the machine's capacities.

# CITYMASTER 2250

This machine simply offers more: more room for the operator, improved ergonomics at the workplace, increased safety, and more application options for even more economic efficiency. Manufactured with high-quality components that meet our own high standards in terms of quality, durability and robustness – and designed with well thought-out concepts that increase profitability and work efficiency.



## Citymaster 2250

Equipped with all-wheel steering, the Citymaster 2250 convinces with more comfort, safety and efficiency in the 6 t class – no matter whether used exclusively as a compact sweeper or as a multifunctional implement carrier for all-season use.



**The new freedom**

The modified bending radius of the large glass surfaces in the upper area of the windscreen provides more headroom and gives the driver an improved sense of space. For greater comfort during long operations – and more work efficiency.



## More room for excellent performance

The control panel with a 6-button key pad and a turn-push regulator integrated in the armrest as well as the 5" colour display provide increased user comfort. In addition, the centre console with reduced switch panel and the uniform right- or left-hand operating concept ensure a clear view onto the attachments and the working area. The slimmed-down control elements create more space, which can be used for optional interior equipment: for example, an auxiliary seat for a co-driver or a transport box for tools.



Made for the driver: Different seat configurations with or without storage compartments provide variable space utilisation options also for left-hand drives.

Keeping a cool head: the excellent air conditioning concept ensures pleasant working conditions even on hot days. In addition, the new light-coloured cabin roof reduces the amount of heat radiation in the head area.

As a further user benefit, the functional armrest can be configured for use in the centre or as a door control unit.

**Benefits for the operator:**

- Maximum freedom of movement
- Individual space utilisation through different interior design variants
- Left- or right-hand operation and flexible positioning of the functional armrest
- Particularly good view onto the working environment thanks to generous glazing
- Pleasant temperatures even on hot days thanks to an optimal ventilation and air conditioning concept and the light-coloured cabin roof.
- Ease-of-use provided by an optimised operating concept: all functions are within easy reach
- More comfort due to the height- and tilt-adjustable steering wheel



## Safe on the road

Working in cities and residential areas presents drivers of municipal machines with challenging traffic situations time and again. Well thought-out details such as full-surface cabin glazing, specifically positioned exterior mirrors, reversing signals and camera systems for an extended viewing angle support the driver in his work and serve to protect pedestrians and other road users. The optional turning (blind spot) assistant is yet another logical decision for best possible safety at work.



### Everything in perfect view

Thanks to full-surface glazing and an intelligent exterior mirror concept, the driver has a particularly good view onto his working environment and to the rear. The 4-Plan mirror system even makes it possible to see the inter-axle area without panoramic mirrors – and without any optical distortion.



### Literally nothing gets overlooked

Optional camera systems allow up to 270° additional viewing angle without the driver taking his eyes off the work at hand. For all-round visibility even when the view is obstructed by attachments and superstructures, more safety on the road, and less collision damage.



More safety when turning right: the optional turning assistant detects cyclists or pedestrians in the blind spot and gives the driver a visual and audible warning signal.

### Technology that saves lives

Whether pedestrians, cyclists or drivers of two-wheeled motorised vehicles: systems such as the optional turning (blind spot) assistant help to avoid potentially dangerous situations in road traffic as well as during municipal applications.

### Your benefits at a glance:

- Improved visibility of the lower working environment
- 4-Plan mirror system for a good view to the rear and the inter-axle area (option)
- 360° view through 270° camera system and turning (blind spot) assistant (options)
- Suction duct camera to check for possible material accumulations (option)
- Heated windscreen for fast defrosting of icing (option)
- Controlled, safe tipping and emptying of the hopper via remote control (option)

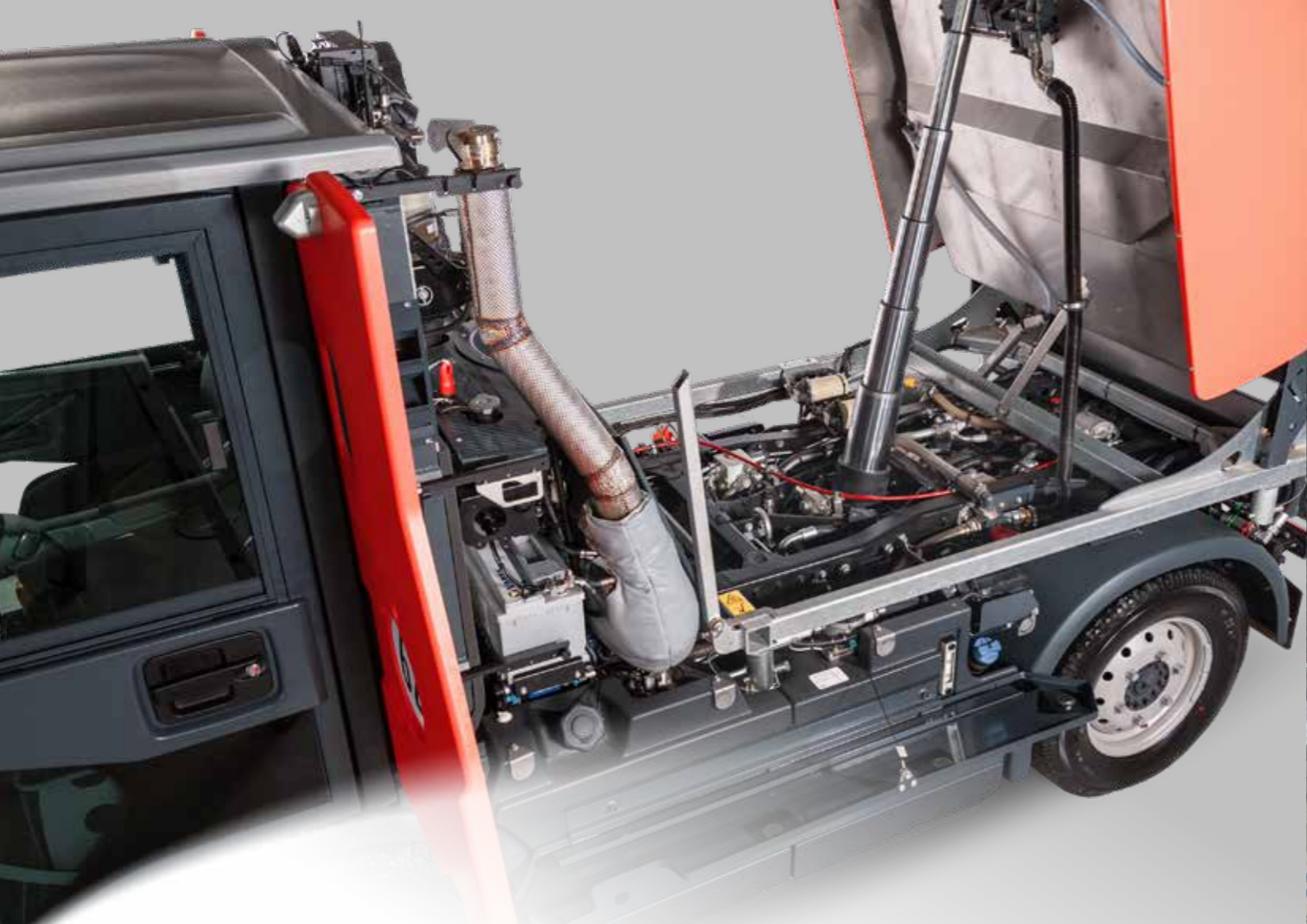

## Safe working in any situation

Safety begins with the vehicle concept. Right from the earliest development phase, we are guided by the highest safety standards and define characteristics for all safety-relevant components. These include the driver's cabin, the chassis with disc brakes or the integrated ABS. At Hako, elaborate tests during and after the development phase are standard business practice – just like our high quality standards in terms of materials and production, which enables us to provide greater safety and durability.



Saves time: with its top speed of 62 km/h, the Citymaster 2250 can also use dual carriageways and national speed limit roads – which significantly reduces travel times from one job site to the next.



### Tested and approved!

To ensure that the driver can feel safe at all times, the new driver's cabin has been ECE-R29-tested, which means that – if the worst comes to the worst – it can withstand even a head-on collision.



To ensure the safety of the driver in any traffic situation, we carry out safety tests to the highest standards.



The anti-lock braking system ensures safe stopping in all road conditions and keeps the vehicle in a stable position during braking. In addition, the Hydrostat ABS provides full traction control with hydraulic traction drive.

### Extremely resilient

Together with the chassis, the sturdy and torsionally flexible frame ensures optimal driving characteristics in all operating situations. Heavy-duty commercial vehicle axles with complex suspension are not only responsible for the high payload of the Citymaster 2250 but also provide increased driving safety during operation.

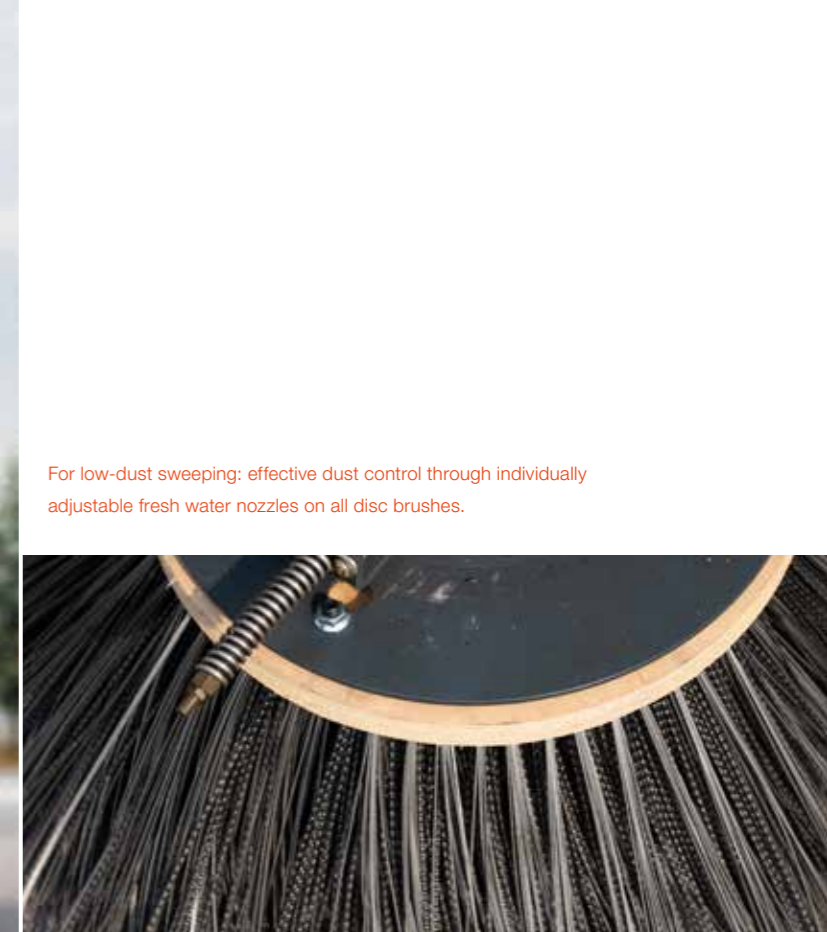

## Perfectly clean on all levels

When used as a sweeper, the capacity of the Citymaster 2250's large 2-m<sup>3</sup> hopper is impressive. Regardless whether the sweeping system is 2 or 3 brooms, both allow maximum flexibility. Even the cleaning of traffic islands or different-level surfaces can be carried out effortlessly.



For reliable and safe results: the roller-guided suction duct with rubber sealing strips increases the dirt pick-up capacity – and at the same time reduces collision damage and wear. In addition, the optional suction duct camera provides information about possible material accumulations.



Powerful: all-wheel steering enables optimal manoeuvring.

## 6 tonnes easily under control!

Despite a gross vehicle weight of 6 tonnes, the Citymaster 2250 is easy to handle: the directionally stable, symmetrical all-wheel steering makes the vehicle extremely manoeuvrable even in cramped operating conditions, and enables precise and close-to-the-edge sweeping.

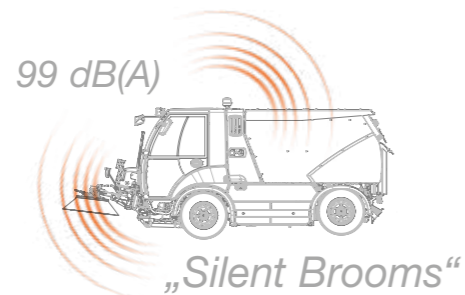

**Hushhh...!**  
Equipped with silent brooms, sweeping is also possible in particularly noise-sensitive areas, for example, near schools or hospitals – even outside office hours or at night!



**D = 2,52 m**  
Great performance, small turning circle: thanks to compact dimensions and all-wheel steering.



The smooth-surfaced stainless-steel hopper allows fast and uncomplicated emptying and is particularly easy to clean.

### Just giving the hopper a quick clean

The large 2m<sup>3</sup> hopper can be filled to 100% – for longer emptying intervals. And when it's finally filled to capacity, it can be emptied easily and safely from the driver's seat – or from the outside via optional remote control for direct monitoring.



The broom sweeps dirt and debris into the path of the suction duct, from where it is sucked directly and safely into the hopper. The suction duct moves forwards and backwards on rollers. The fresh and circulation water system provides effective dust control.



## Ready for any big task

Sweeping, wet cleaning, winter service: designed for all-season use, the City-master 2250 is particularly economically efficient. Thanks to the quick-change system, the vehicle can be quickly and easily re-tooled for different applications: for example, with a scrubbing deck for removing stubborn dirt, or with a snow blade, front sweeper and silo gritter or a brine spray system to fight snow and ice.



Chemical-free against weeds: with a weed broom for mechanical removal and collection of weeds.



Wet cleaning made easy: the scrubbing deck removes even stubborn dirt from smooth surfaces.



Sweeping 2 brooms



Sweeping 3 brooms



Weed broom



Dirt sweeping cylinder



Snow blade



Snow plough



Snow sweeping cylinder



Sluicing



Scrubbing



Collecting leaves



High-pressure cleaner

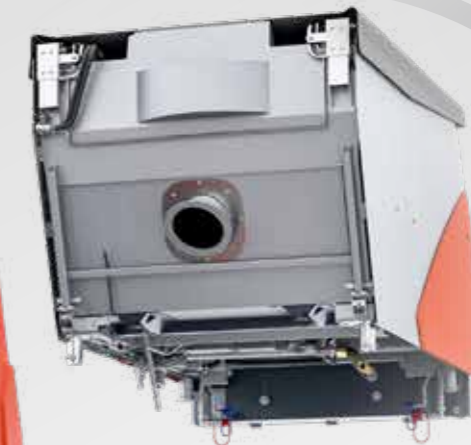

Gritter



Brine sprayer



Trailer

### Your benefits at a glance:

- More economic efficiency: only one optimally designed machine for a wide range of applications
- More flexibility: attachments and superstructures for every cleaning task
- More comfort: fast, uncomplicated and tool-free changing of attachments thanks to the quick-change system
- Less effort: significantly reduced configuration and training times through a consistent technical basis





**Hako-approved spare parts – here's why:**

- Product and service quality from a single source
- Perfectly matched parts for superior efficiency
- Safe and reliable operation – guaranteed!
- Saves costs through minimised downtimes as well as repair and maintenance times
- Full support through top qualified Hako service technicians
- Guaranteed compliance with norms and standards



## Always there for you!

To ensure that our machines deliver optimum performance at all times, we are there for you with our Hako Service whenever you need us. We offer you the security you need in advance – with individual service and maintenance agreements. And in the event of minor faults, a Hako service professional with a fully equipped service vehicle is quickly on site.



**Your service benefits:**

- Top qualified service technicians with fully equipped service vehicles
- Overnight delivery of Hako-approved spare parts
- Delivery and pick-up service as well as rental and bridging machines
- Individual service and maintenance agreements
- Customer proximity with a nation-wide network of subsidiaries, authorised dealers and service partners

**Our professionals for your machine**

Maximum availability through minimum workshop visits: regular maintenance and repairs are carried out exclusively by experienced and trained service technicians in modern workshops in our subsidiaries, at our authorised dealers and at authorised Hako service partners.



## Technical data

Citymaster 2250 – 2-broom variant

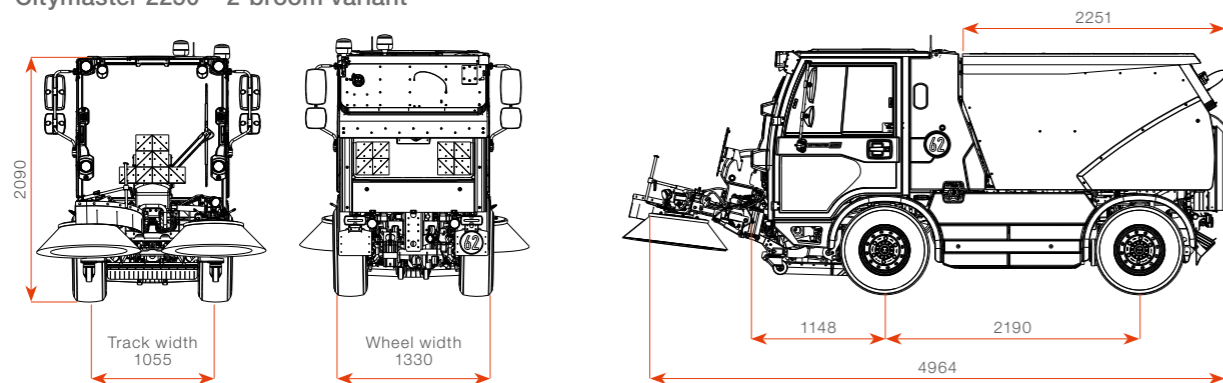

Citymaster 2250 – 3-broom variant

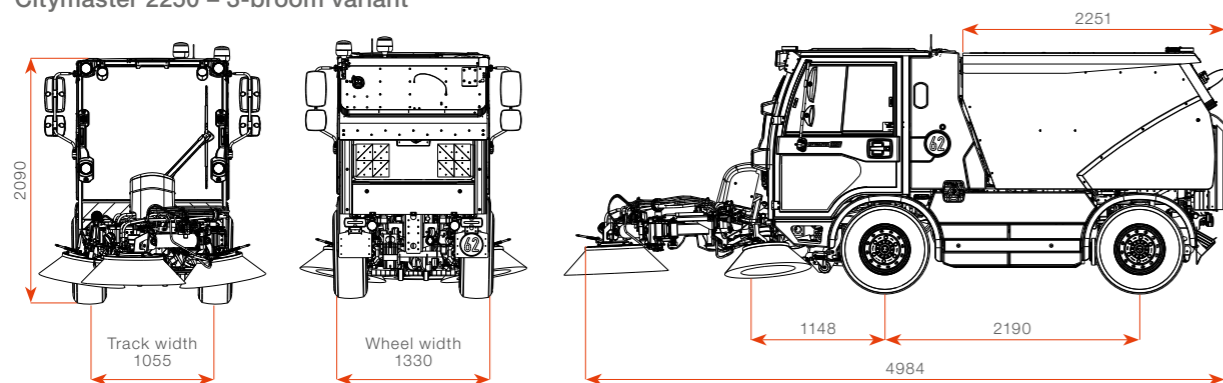

		Citymaster 2250 2B	Citymaster 2250 3B
Engine and drive	Engine	<ul style="list-style-type: none"> <li>• VM R754 EU6 D3 four-cylinder – turbo diesel according to directive 595/2009/EC EURO VI intercooler</li> <li>• Diesel oxi-cat (DOC), particle filter, SCR cat, tank capacity 65 l</li> </ul>	
	Cubic capacity/output	• 2,970 cm <sup>3</sup> / 80 kW (109 HP) at 2,600 RPM	
	Max. torque	• 420 Nm at 1,100 RPM	
Driving and working characteristics	Traction drive	<ul style="list-style-type: none"> <li>• Fully hydraulic traction drive, rear-wheel drive, engageable all-wheel steering</li> <li>• Differential lock optional, 3 operating modes: transport mode with automatic speed (rpm) and load control, work mode with constant speed, offset driving mode with constant speed (rpm), top speed transport journeys 62 km/h</li> <li>• Standard steering offset driving up to 25 km/h, all-wheel steering work-driving up to 15 km/h, all-wheel steering reverse driving up to 10 (25) km/h</li> </ul>	
	Work drive	<ul style="list-style-type: none"> <li>• Load sensing high-pressure hydraulics with variable power distribution</li> <li>• 3 performance levels: ECO/Standard/MAX, selectable at the push of a button</li> <li>• Fan with engine-independent speed (rpm) control</li> <li>• Additional functions via optional multi-purpose package</li> </ul>	
	Attachment interfaces	• Quick-change triangle Cat.0 at the front, ball changing system at the rear	
	Frame, chassis, brakes	<ul style="list-style-type: none"> <li>• Commercial vehicle ladder frame with 2 steering axles, coil springs with shock absorbers</li> <li>• Stabiliser at the rear axle, 4 pick-up points for standard lifting platforms</li> <li>• 2-circuit braking system with 4 disc brakes and brake booster</li> <li>• ABS linked to Hydrostat, variable hydrostatic braking power, independent mechanical parking brake, acting on the rear axle</li> </ul>	
	Wheels and tyres	<ul style="list-style-type: none"> <li>• Standard tyres 225/75 R16C</li> <li>• Wide tyres 285/65 R16C</li> </ul>	
	Cabin	<ul style="list-style-type: none"> <li>• 2-seater comfort cabin, occupant protection tested according to ECE-R 29</li> <li>• Steering column with 2 adjustment options</li> <li>• Comfort seats, 3-point safety belt</li> <li>• Comfortable 1-hand operation of all sweeping functions</li> <li>• 1-button operating system starts all sweeping functions</li> <li>• Automatically saves all operating parameters</li> </ul>	
	Sweeping system	<ul style="list-style-type: none"> <li>• 2 brooms 900 mm</li> <li>• Working width up to 2,500 mm</li> <li>• Suction duct 800 mm on rollers</li> </ul>	<ul style="list-style-type: none"> <li>• Pre-sweep broom 900 mm, 2 basic brooms 750 mm,</li> <li>• Working width up to 2,600 mm</li> <li>• Suction duct 800 mm on rollers</li> </ul>
Hopper	<ul style="list-style-type: none"> <li>• Stainless steel V2A dirt hopper 2.2 m<sup>3</sup></li> <li>• Gross capacity 1,895 l</li> <li>• Usable hopper capacity 1,710 l</li> </ul>		
Dimensions and load values	Length/width/height*	4,964 mm / 1,330 mm / 2,090 mm	4,984 mm / 1,330 mm / 2,090 mm
	Wheelbase/traction width	2,190 mm / 1,054 mm	
	Gross vehicle weight (GVW)	6,000 kg	
	Permitted axle loads	3,200 kg / 3,200 kg	
	Empty weight**	3,610 kg	3,710 kg
	Payload***	up to 2,390 kg	up to 2,290 kg

Form, colour and design are subject to change without notice in favour of further technical development. Pictures may show optional extras. Services and products may vary from country to country. Data according to EN 15429 1-4, where applicable.

\* Width: without wing mirrors, height: with standard tyres  
 \*\* Empty weight: standard machine without optional extras  
 \*\*\* Payload: optional extras may reduce the payload



## Economically efficient right from the start

### Hako-Fleet-Management

Hako's online-based fleet management system records and centrally processes all important key data of the machines in your fleet. The stored information can be accessed at any time via your PC or mobile devices. view.X enables the economical use and management of the machine fleet. In addition, view.X.live transmits important operating data almost in real time. The optional electronic machine access authorisation module entry.X only allows authorised users to use the machine.



### Attractive financing alternatives

High-performance machines and excellent service in a complete package with fixed calculable costs over the entire period of use. Tailored to your individual needs and with maximum flexibility.



Leasing options – customised to meet individual customer requirements.

Rental contract  
ALL-IN-plus: financing, maintenance and insurance included!

Hire-purchase – customised monthly payments in line with your liquidity.

Adapt your rental payments to your seasonal earnings.

Hako Machines Ltd  
Eldon Close,  
Crick, Northampton  
NN6 7UD  
**01788 825600**  
**enquiries@hako.co.uk**  
**www.hako.co.uk**



Blue Competence is an initiative of VDMA (www.vdma.org). By engaging in this partnership, we are committed to comply with the twelve sustainability principles applied in the field of mechanical and system engineering (www.bluecompetence.net/about).